

STIHL

STIHL FR 131 T

Instruction Manual



Contents

Guide to Using this Manual	2	Maintenance and Repairs	39
Safety Precautions and Working Techniques	2	Disposal	40
Approved Combinations of Cutting Attachment, Deflector and Handle	12	EC Declaration of Conformity	40
Approved KombiTools	13		
Assembling the Unit	14		
Adjusting the Throttle Cable	16		
Mounting the KombiTool	16		
Mounting the deflector	17		
Mounting the Cutting Attachment	18		
Fuel	21		
Fueling	22		
Support frame	22		
Starting / Stopping the Engine	24		
Transporting the Unit	26		
Operating Instructions	28		
Replacing the Air Filter	28		
Adjusting the Carburetor	28		
Spark Plug	29		
Engine Running Behavior	30		
Lubricating the Gearbox	30		
Lubricating the Flexible Shaft	30		
Storing the Machine	31		
Sharpening Metal Cutting Blades	31		
Maintaining the Mowing Head	32		
Inspections and Maintenance by Dealer	33		
Maintenance and Care	34		
Minimize Wear and Avoid Damage	36		
Main Parts	37		
Specifications	38		

Dear Customer,

Thank you for choosing a quality engineered STIHL product.

It has been built using modern production techniques and comprehensive quality assurance. Every effort has been made to ensure your satisfaction and trouble-free use of the product.

Please contact your dealer or our sales company if you have any queries concerning this product.

Your



Dr. Nikolas Stihl

STIHL

This instruction manual is protected by copyright. All rights reserved, especially the rights to reproduce, translate and process with electronic systems.

Guide to Using this Manual

Pictograms

The meanings of the pictograms attached to the machine are explained in this manual.

Depending on the model concerned, the following pictograms may be attached to your machine.



Fuel tank; fuel mixture of gasoline and engine oil



Operate decompression valve



Manual fuel pump

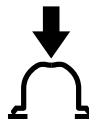

Operate manual fuel pump

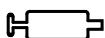

Tube of grease



Intake air: Summer operation



Intake air: Winter operation



Handle heating

Symbols in text



WARNING

Warning where there is a risk of an accident or personal injury or serious damage to property.



NOTICE

Caution where there is a risk of damaging the machine or its individual components.

Engineering improvements

STIHL's philosophy is to continually improve all of its products. For this reason we may modify the design, engineering and appearance of our products periodically.

Therefore, some changes, modifications and improvements may not be covered in this manual.

Safety Precautions and Working Techniques



Some special safety precautions must be observed to reduce the risk of personal injury when operating this power tool because of the very high speed of its cutting attachment.



It is important that you read the instruction manual before first use and keep it in a safe place for future reference. Non-observance of the instruction manual may result in serious or even fatal injury.

Observe all applicable local safety regulations, standards and ordinances.

If you have not used this type of power tool before: Have your dealer or other experienced user show you how it is operated or attend a special course in its operation.

Minors should never be allowed to use a power tool.

Keep bystanders, especially children, and animals away from the work area.

When the power tool is not in use, shut it off so that it does not endanger others. Secure it against unauthorized use.

The user is responsible for avoiding injury to third parties or damage to their property.

Do not lend or rent your power tool without the instruction manual. Be sure that anyone using it understands the information contained in this manual.

The use of noise emitting power tools may be restricted to certain times by national or local regulations.

To operate the power tool you must be rested, in good physical condition and mental health.

If you have any condition that might be aggravated by strenuous work, check with your doctor before operating a power tool.

Persons with pacemakers only: The ignition system of your power tool produces an electromagnetic field of a very low intensity. This field may interfere with some pacemakers. STIHL recommends that persons with pacemakers consult their physician and the pacemaker manufacturer to reduce any health risk.

Do not operate the power tool if you are under the influence of any substance (drugs, alcohol) which might impair vision, dexterity or judgment.

Depending on the cutting attachment fitted, use your power tool only for cutting grass, wild growth, shrubs, scrub, bushes, small diameter trees and similar materials.

Do not use your power tool for any other purpose because of the **increased risk of accidents**.

Only use cutting attachments and accessories that are explicitly approved for this power tool model by STIHL or are technically identical. If you have any questions in this respect, consult a

servicing dealer. Use only high quality tools and accessories in order to avoid the risk of accidents and damage to the machine.

STIHL recommends the use of genuine STIHL tools and accessories. They are specifically designed to match the product and meet your performance requirements.

The deflector on this power tool cannot protect the operator from all objects thrown by the cutting attachment (stones, glass, wire, etc.). Such objects may ricochet and then hit the operator.

Never attempt to modify your machine in any way since this may increase the risk of personal injury. STIHL excludes all liability for personal injury and damage to property caused while using unauthorized attachments.

Do not use a pressure washer to clean your power tool. The solid jet of water may damage parts of the power tool.

Clothing and Equipment

Wear proper protective clothing and equipment.



Clothing must be sturdy but allow complete freedom of movement. Wear snug-fitting clothing, an overall and jacket combination, do not wear a work coat.

Avoid clothing that could get caught on branches or brush or moving parts of the machine. Do not wear a scarf, necktie or jewelry. Tie up and confine long hair (e.g. with a hair net, cap, hard hat, etc.).



Wear steel-toed safety boots with non-slip soles.

Sturdy shoes with non-slip soles may be worn as an alternative only when using mowing heads.



WARNING



To reduce the risk of eye injuries, wear close-fitting safety glasses in accordance with European Standard EN 166. Make sure the safety glasses are a comfortable and snug fit.

Wear a face shield and make sure it is a good fit. A face shield alone does not provide adequate eye protection.

Wear a safety hard hat for thinning operations, when working in high scrub and where there is a danger of head injuries from falling objects.

Wear hearing protection, e.g. earplugs or ear muffs.



Wear heavy-duty work gloves made of durable material (e.g. leather).

STIHL offers a comprehensive range of personal protective clothing and equipment.

Transporting the Power Tool

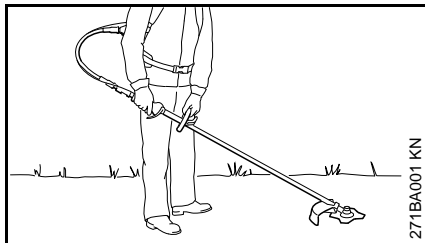

Turn off the engine before transporting the unit over distances of more than about 50 meters.

Carry the unit in the normal working position: Power tool on your back, left hand on the loop handle and the right hand on the control handle – even if you are left-handed – cutting attachment lowered close to ground.

To reduce the risk of cut injuries, fit transport guard on the cutting attachment, even when carrying the tool for short distances – see also "Transporting the Unit".



To reduce the risk of serious burn injuries, avoid touching hot parts of the machine, including the gearbox housing.

Transporting by vehicle: Properly secure your power tool to prevent turnover, fuel spillage and damage.

Fueling



Gasoline is an extremely flammable fuel. Keep clear of naked flames. Do not spill any fuel – do not smoke.

Always shut off the engine before refueling.

Do not fuel a hot engine – fuel may spill and **cause a fire**.

Open the fuel cap carefully to allow any pressure build-up in the tank to release slowly and avoid fuel spillage.

Fuel your power tool only in well-ventilated areas. If you spill fuel, wipe the machine immediately – if fuel gets on your clothing, change immediately.





After fueling, tighten down the fuel tank cap as securely as possible.

This reduces the risk of unit vibrations causing the fuel cap to loosen or come off and spill quantities of fuel.

To reduce the risk of serious or fatal burn injuries, check for fuel leakage. If fuel leakage is found, do not start or run the engine until leak is fixed.

Before Starting

Check that your power tool is properly assembled and in good condition – refer to appropriate chapters in the instruction manual.

- Check the fuel system for leaks, paying special attention to visible parts such as the tank cap, hose connections and the manual fuel pump (on machines so equipped). If there are any leaks or damage, do not start the engine – **risk of fire**. Have your machine repaired by a servicing dealer before using it again.
- Use only an approved combination of cutting attachment, deflector and handle. All parts must be assembled properly and securely.
- The stop switch must move freely.
- Check smooth action of choke knob, throttle trigger lockout and throttle trigger – the throttle trigger must return automatically to the idle position. The choke knob must spring back from the  and  positions to the run position **I** when the throttle trigger lockout and throttle trigger are squeezed.
- Check that the spark plug boot is secure – a loose boot may cause arcing that could ignite combustible fumes **and cause a fire**.

- Check cutting tool or attachment for correct and secure assembly and good condition.
- Check protective devices (e.g. deflector for cutting attachment, rider plate) for damage or wear. Always replace damaged parts. Do not operate your machine with a damaged deflector or worn rider plate (lettering and arrows no longer legible).
- Never attempt to modify the controls or safety devices in any way.
- Keep the handles dry and clean – free from oil and dirt – for safe control of the power tool.
- Adjust straps and loop handle to suit your height and reach – see chapter on "Fitting the Backpack".
- Check condition of carrying system and the straps - replace if damaged or worn.

To reduce the risk of accidents, do not operate your power tool if it is damaged or not properly assembled.

For emergencies: Practice quickly opening the fastener on the waist belt, loosening the shoulder straps and setting down the unit. To avoid damage, do not throw the machine to the ground when practicing.

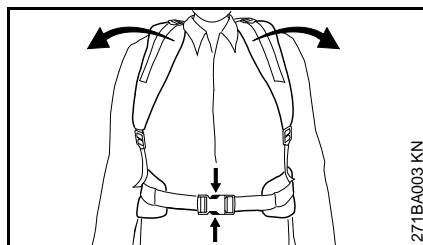

Starting the Engine

Start the engine at least 3 meters from the fueling spot, outdoors only.

Place the powerhead on firm ground in an open area. Make sure you have good balance and secure footing. Hold the powerhead securely. The cutting attachment must be clear of the ground and all other obstructions because it may begin to run when the engine starts. Observe information in chapter on "Starting / Stopping the Engine".

Your power tool is a one-person unit. **To reduce the risk of injury** from thrown objects, do not allow other persons within a radius of 15 meters of your own position – even when starting.



To reduce the risk of injury, avoid contact with the cutting attachment.

Do not drop start the power tool – start the engine as described in the instruction manual.



Note that the cutting attachment continues to run for a short period after you let go of the throttle trigger – **flywheel effect**.

Check idle speed setting: The cutting attachment must not rotate when the engine is idling with the throttle trigger released.

To reduce the risk of fire, keep hot exhaust gases and hot muffler away from easily combustible materials (e.g. wood chips, bark, dry grass, fuel).

Holding and Controlling the Power Tool

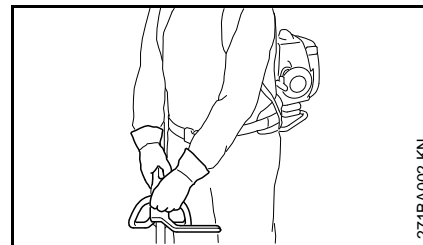

Make sure you always have good balance and secure footing.

Carry the powerhead on your back. **To reduce the risk of injury**, put the powerhead on your back only after starting and making sure the cutting attachment is not rotating.

Always hold the drive tube firmly with both hands on the handles – right hand on control handle and left hand on loop handle – and always keep the drive tube on the right side of your body – even if you are left-handed.

During Operation

In the event of imminent danger or in an emergency, switch off the engine immediately – operate the stop switch.

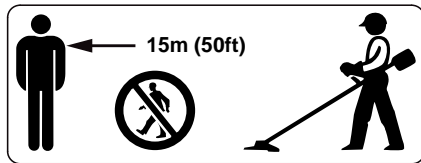

To reduce the risk of injury from thrown objects, do not allow any other persons within 15 meters of your own position.

To reduce the risk of damage to property, also maintain this distance from other objects (vehicles, windows).

The correct engine idle speed is important to ensure that the cutting attachment stops rotating when you let go of the throttle trigger. Check and correct the idle speed setting regularly. If the cutting attachment continues to rotate when the engine is idling, have the machine checked by your servicing dealer. STIHL recommends an authorized STIHL servicing dealer.

Take special care in slippery conditions (ice, wet ground, snow), on slopes or uneven ground.

Watch out for obstacles: Roots and tree stumps which **could cause you to trip or stumble**.

Make sure you always have good balance and secure footing.

Never work on a ladder or in a tree.

Never operate your power tool with one hand.

Be particularly alert and cautious when wearing hearing protection because your ability to hear warnings (shouts, alarms, etc.) is restricted.

To reduce the risk of accidents, take a break in good time to avoid tiredness or exhaustion.

Work calmly and carefully – in daylight conditions and only when visibility is good. Stay alert so as not to endanger others.



Your power tool produces toxic exhaust fumes as soon as the engine is running. These fumes may be colorless and odorless and contain unburned hydrocarbons and benzol. Never run the engine indoors or in poorly ventilated locations, even if your model is equipped with a catalytic converter.

Ensure proper ventilation when working in trenches, hollows or other confined locations. **This reduces the risk of serious or fatal injury from breathing toxic fumes.**

To reduce the risk of accidents, stop work immediately in the event of nausea, headache, visual disturbances (e.g. reduced field of vision), problems with hearing, dizziness, deterioration in ability to concentrate. Apart from other possibilities, these symptoms may be caused by an excessively high concentration of exhaust gases in the work area.

Operate your power tool so that it produces a minimum of noise and emissions – do not run the engine unnecessarily, accelerate the engine only when working.

To reduce the risk of fire, do not smoke while operating or standing near your power tool. Note that combustible fuel vapor may escape from the fuel system.

The dusts, vapor and smoke produced during operation may be dangerous to health. If the work area is very dusty or smoky, wear a respirator.

If your power tool is subjected to unusually high loads for which it was not designed (e.g. heavy impact or a fall), always check that it is in good condition before continuing work – see also "Before Starting".

Check the fuel system in particular for leaks and make sure the safety devices are working properly. Do not continue operating your power tool if it is damaged. In case of doubt, consult your servicing dealer.

Do not operate your power tool in the starting throttle position – engine speed cannot be controlled in this position.



To reduce the risk of injury from thrown objects, never operate the unit without the proper deflector for the type of cutting attachment being used.



Inspect the work area: Stones, pieces of metal or other solid objects can be thrown and **cause personal injury** or damage the cutting attachment and property (e.g. parked vehicles, windows).



Special care must be taken when working in difficult, over-grown terrain.

When cutting high scrub, under bushes and hedges: Keep cutting attachment at a minimum height of 15 cm to avoid harming small animals.

Before leaving the power tool unattended: Shut off the engine.

Check the cutting attachment at regular short intervals during operation or immediately if there is a noticeable change in cutting behavior:

- Turn off the engine. Hold the unit firmly and wait for the cutting attachment to come to a standstill.
- Check condition and tightness, look for cracks.
- Check sharpness.
- Replace damaged or dull cutting attachments immediately, even if they have only superficial cracks.

Clean grass and plant residue off the cutting attachment mounting at regular intervals – remove any build up of material from the cutting attachment and deflector.

To reduce the risk of injury, shut off the engine before changing the cutting attachment.



The gearbox gets hot during operation. **To reduce the risk of burn injury**, do not touch the gearbox housing.

When using mowing heads

Equip the deflector with the additional components specified in the instruction manual.

Use only the deflector with properly mounted line limiting blade to ensure the mowing lines are automatically trimmed to the approved length.

To reduce the risk of injury, always turn off the engine before adjusting the nylon line of manually adjustable mowing heads.

Using the unit with over-long nylon cutting lines reduces the engine's operating speed. The clutch then slips continuously and this causes overheating and damage to important components (e.g. clutch, polymer housing components) – **and this can increase the risk of injury** from the cutting attachment rotating while the engine is idling.

Using metal cutting attachments

STIHL recommends the use of original STIHL metal cutting attachments. They are specifically designed to match your model and meet your performance requirements.

Metal cutting attachments rotate at very high speed. The forces that occur act on the machine, the attachment and the material being cut.

Sharpen metal cutting attachments regularly as specified.

Unevenly sharpened metal cutting attachments cause out-of-balance which can impose extremely high loads on the machine and increase the **risk of breakage**.

Dull or improperly sharpened cutting edges can put a higher load on the cutting attachment and increase the **risk of injury** from cracked or broken parts.

Inspect metal cutting attachments for cracks or warping after every contact with hard objects (e.g. stones, rocks, pieces of metal). **To reduce the risk of injury**, remove burrs and other visible build-ups of material (use a file) because they may become detached and be thrown at high speed during operation.

If a rotating metal cutting attachment makes contact with a rock or other solid object there is a risk of sparking which may cause easily combustible material to catch fire under certain circumstances. Dry plants and scrub are also easily combustible, especially in hot and dry weather conditions. If there is a risk of fire, do not use metal cutting attachments near combustible materials, dry plants or scrub. Always contact your local forest authority for information on a possible fire risk.

Do not continue using or attempt to repair damaged or cracked cutting attachments by welding, straightening or modifying the shape (out of balance).

This may cause parts of the cutting attachment to come off and hit the operator or bystanders at high speed and **result in serious or fatal injuries**.

To reduce the above-mentioned risks when using a metal cutting attachment, never use a metal cutting attachment with a diameter larger than specified. It must not be too heavy. It must be manufactured from materials of adequate quality and its geometry must be correct (shape, thickness).

To reduce the risk of injury, a metal cutting attachment not manufactured by STIHL must not be heavier, thicker, have a different shape or a diameter larger than the largest metal cutting attachment approved by STIHL for this power tool model.

Vibrations

Prolonged use of the power tool may result in vibration-induced circulation problems in the hands (whitefinger disease).

No general recommendation can be given for the length of usage because it depends on several factors.

The period of usage is prolonged by:

- Hand protection (wearing warm gloves)
- Work breaks

The period of usage is shortened by:

- Any personal tendency to suffer from poor circulation (symptoms: frequently cold fingers, tingling sensations).
- Low outside temperatures.
- The force with which the handles are held (a tight grip restricts circulation).

Continual and regular users should monitor closely the condition of their hands and fingers. If any of the above symptoms appear (e.g. tingling sensation in fingers), seek medical advice.

Maintenance and Repairs

Service the machine regularly. Do not attempt any maintenance or repair work not described in the instruction manual. Have all other work performed by a servicing dealer.

STIHL recommends that you have servicing and repair work carried out exclusively by an authorized STIHL servicing dealer. STIHL dealers are regularly given the opportunity to attend training courses and are supplied with the necessary technical information.

Only use high-quality replacement parts in order to avoid the risk of accidents and damage to the machine. If you have any questions in this respect, consult a servicing dealer.

STIHL recommends the use of original STIHL replacement parts. They are specifically designed to match your model and meet your performance requirements.

To reduce the risk of injury from unintentional engine startup, **always shut off the engine and disconnect the spark plug boot** before performing any repairs, maintenance or cleaning work. – Exception: Carburetor and idle speed adjustments.

Do not turn the engine over on the starter with the spark plug boot or spark plug removed since there is otherwise a **risk of fire** from uncontained sparking.

To reduce the **risk of fire**, do not service or store your machine near open flames.

Check the fuel filler cap for leaks at regular intervals.

Use only a spark plug of the type approved by STIHL and make sure it is in good condition – see "Specifications".

Inspect the ignition lead (insulation in good condition, secure connection).

Check the condition of the muffler.

To reduce the **risk of fire and damage to hearing**, do not operate your machine if the muffler is damaged or missing. –

Do not touch a hot muffler since **burn injury** will result.

Vibration behavior is influenced by the condition of the AV elements – check the AV elements at regular intervals.

Symbols on Deflectors

An **arrow** on the deflector shows the correct direction of rotation of the cutting attachments.

Some of the following symbols are applied to the outside of the deflector to indicate the approved combination of cutting attachment and deflector.



Deflector may be used with mowing heads.



Deflector must not be used with mowing heads.



Deflector may be used with grass cutting blades.



Deflector must not be used with grass cutting blades.



Deflector may be used with brush knives.



Deflector must not be used with brush knives.



Deflector must not be used with shredder blades.



Deflector must not be used with circular saw blades.

Mowing Head with Nylon Line

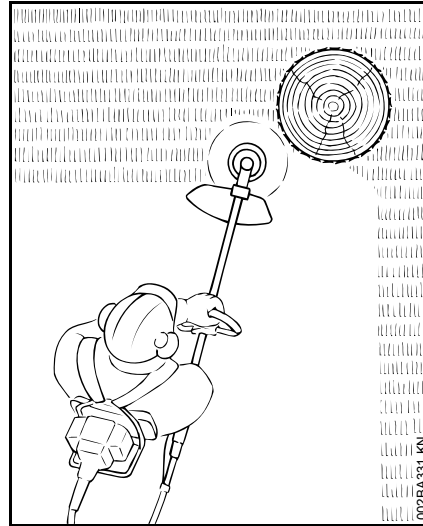

Nylon line achieves a soft cut for edging and trimming around trees, fence posts, etc. – less risk of damaging tree bark.

The mowing head comes with an instruction leaflet. Refill the mowing head with nylon line as described in the instruction leaflet.

! WARNING

To reduce the risk of serious injury, never use wire or metal-reinforced line in place of the nylon line.

STIHL Polycut Mowing Head with Polymer Blades

For mowing unobstructed edges of meadows (without posts, fences, trees or similar obstacles).

Check the wear limit marks!

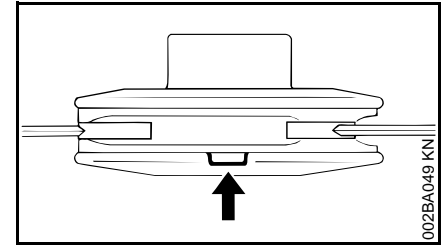

If one of the wear limit marks on the PolyCut mowing head is worn through (arrow): Do not continue using the mowing head. Install a new one. There is otherwise a **risk of injury** from thrown parts of the head.

It is important to follow the maintenance instructions for the PolyCut mowing head.

The PolyCut can also be equipped with mowing line in place of the polymer blades.

The mowing head comes with instruction leaflets. Equip the mowing head with polymers blades or nylon line as described in the instruction leaflets.

! WARNING

Never use wire in place of the nylon mowing line – **risk of injury**.

Risk of Kickout (Blade Thrust) with Metal Cutting Attachments

! WARNING



When using metal cutting attachments there is a risk of kickout when the rotating blade comes into contact with a solid object such as a tree trunk, branch, tree stump, rock or similar. The machine is thrown to the right or to the rear – opposite to the attachment's direction of rotation.

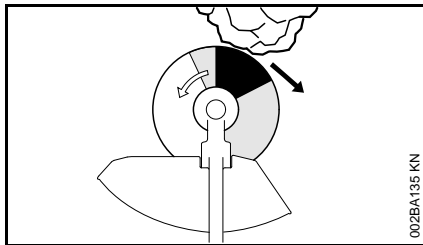

The **risk of kickout is greatest** when the **black area** of the rotating cutting attachment comes into contact with a solid object.

Grass Cutting Blade

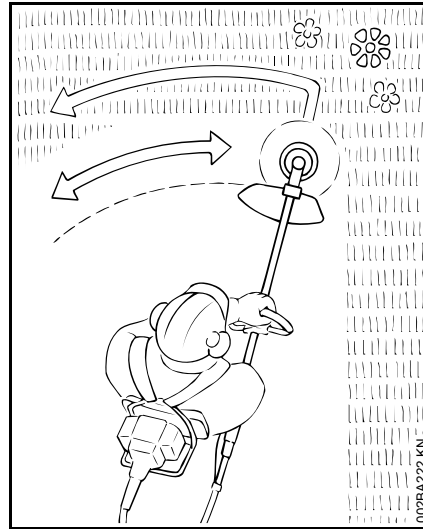

Use for grass and weeds only – sweep the brushcutter in an arc like a scythe.

! WARNING

Improper use may damage the grass cutting blade – **risk of injury** from thrown parts.

Resharpener the grass cutting blade according to instructions when it has dulled noticeably.

Brush Knife

For cutting matted grass, wild growth and scrub and thinning young stands with a stem diameter of no more than 2 cm – do not cut thicker stems – **risk of accidents**.

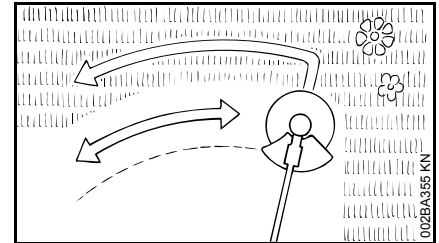

Use the brushcutter like a scythe (sweep it to the right and left) at ground level when cutting grass and thinning young stands.

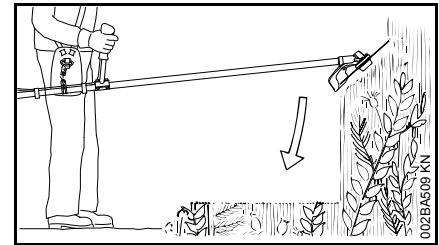

To cut wild growth and scrub, lower the brush knife down onto the growth to achieve a shredding effect – always keep the cutting attachment below hip level during this process.













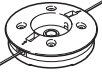
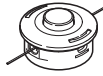



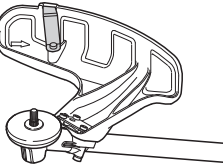
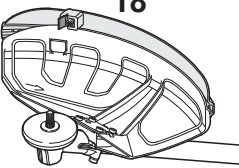
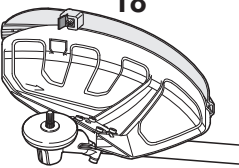

Exercise extreme caution when using this method of cutting. The higher the cutting attachment is off the ground, the greater the risk of injury from cuttings being thrown sideways.

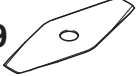
Warning! Improper use of a brush knife may cause it to crack, chip or shatter – **risk of injury** from thrown parts.

To reduce the risk of injury it is essential to take the following precautions:

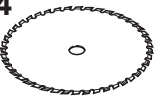
- Avoid contact with stones, rocks, pieces of metal and other solid foreign objects.
- Never cut wood or shrubs with a stem diameter of more than 2 cm – use a circular saw blade for such work.
- Inspect the brush knife at regular short intervals for signs of damage. Do not continue working with a damaged brush knife.
- Resharpener the brush knife regularly and whenever it has dulled noticeably, and have it balanced if necessary (STIHL recommends a STIHL servicing dealer).

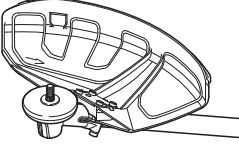
Approved Combinations of Cutting Attachment, Deflector and Handle

Cutting Attachment		Deflector	Handle
   	   	  	  
  	   		 

0000-GXX-1294-A0

Approved Combinations

Select correct combination from the table according to the cutting attachment you intend to use.



WARNING

For safety reasons only the cutting attachments, deflectors and handles shown in each row of the table may be used together. No other combinations are permitted – **risk of accidents.**

Cutting Attachments

Mowing heads

- 1 STIHL SuperCut 20-2
- 2 STIHL AutoCut 25-2
- 3 STIHL AutoCut C 25-2
- 4 STIHL AutoCut C 26-2
- 5 STIHL AutoCut 36-2

- 6 STIHL TrimCut 31-2
- 7 STIHL DuroCut 20-2
- 8 STIHL PolyCut 20-3

Metal cutting attachments

- 9 Grass cutting blade 230-2
(230 mm dia.)
- 10 Grass cutting blade 260-2
(260 mm dia.)
- 11 Grass cutting blade 230-4
(230 mm dia.)
- 12 Grass cutting blade 230-8
(230 mm dia.)
- 13 Grass cutting blade 250-40 Spezial
(250 mm dia.)
- 14 Grass cutting blade 250-44
(250 mm dia.)
- 15 Brush knife 250-3
(250 mm dia.)



WARNING

Non-metal grass cutting blades and brush knives are not approved.

Deflectors

- 16 Deflector for mowing heads
- 17 Deflector **with**
- 18 skirt and blade, for mowing heads
- 19 Deflector **without** skirt and blade, for metal cutting attachments

Handle

- 20 Loop handle (for non-EU countries only)

- 21 Loop handle **with**
- 22 Barrier bar

Approved KombiTools

KombiTools are power tool attachments from the STIHL KombiSystem.

Only use KombiTools supplied by STIHL or expressly approved by STIHL for use with your specific model.

Only the following KombiTools may be mounted to this STIHL brushcutter with a split drive tube (T model):

KombiTool	Application
FS-KM ⁴⁾	Brushcutter with mowing head
FS-KM ^{1) 4)}	Brushcutter with grass cutting blade
HL-KM 145°	Long reach hedge trimmer, adjustable
HL-KM 0° ³⁾	Long reach hedge trimmer
FH-KM 145°	Power scythe, adjustable
BG-KM	Blower
HT-KM	Pole pruner
BF-KM	Cultivator with pick tines
FCB-KM ²⁾	Edger
FCS-KM ⁴⁾	Edger

1) the barrier bar on the loop handle supplied with the machine must be used – see also "Mounting the Loop Handle"

2) Version with curved drive tube

3) Less suitable for ergonomic reasons

4) Version with straight drive tube

Assembling the Unit

Mounting the Support Frame

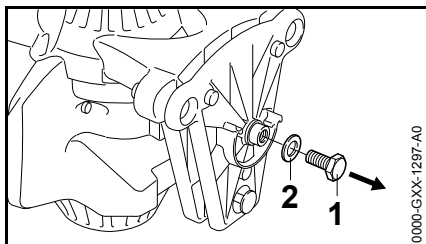

- Loosen and remove the screw (1) with washer (2) from the powerhead.

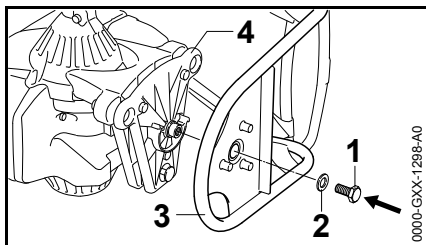

- Line up the powerhead and support frame as shown.
- Insert the screw (1) with washer (2) and tighten it down firmly.

Installing the Flexible Shaft

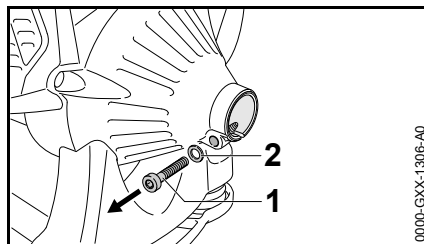

- Unscrew the screw (1) and remove it with the washer (2).

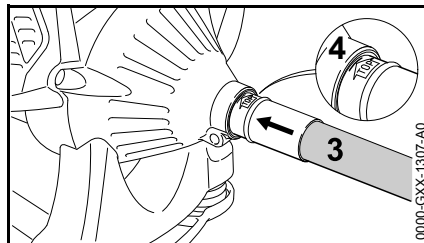

- Pull the protective cap off the shaft.
- Push the flexible shaft fully into the powerhead (4) – turn the shaft back and forth at the same time.
- Line up the flexible shaft – the word "Top" must face up.

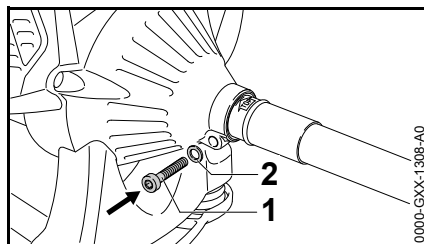

- Insert the screw (1) with washer (2) and tighten it down firmly.

Mounting Loop Handle with Barrier Bar

A barrier bar may have to be mounted to the loop handle to suit the market and the cutting attachment you intend to use – see "Approved Combinations of Cutting Attachment, Deflector and Handle".

The barrier bar comes standard with the machine or is available as a special accessory.

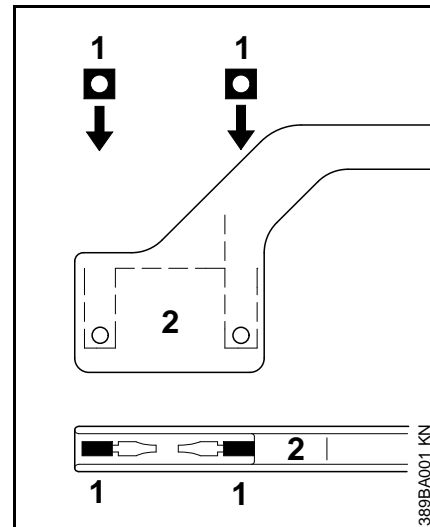

- Fit the square nuts (1) in the barrier bar (2) – make sure the holes line up.

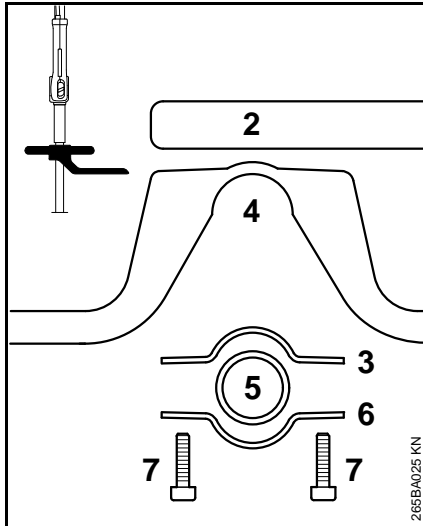

- Place the clamp (3) in the loop handle (4) and position them both against the shaft (5).
- Position the clamp (6) against the shaft.
- Place the barrier bar (2) in position as shown.
- Line up the holes.
- Insert the screws (7) in the holes and screw them into the barrier bar as far as stop.
- Go to "Securing the Loop Handle".

Leave the barrier bar permanently mounted to the loop handle.

Mounting the Loop Handle without Barrier Bar

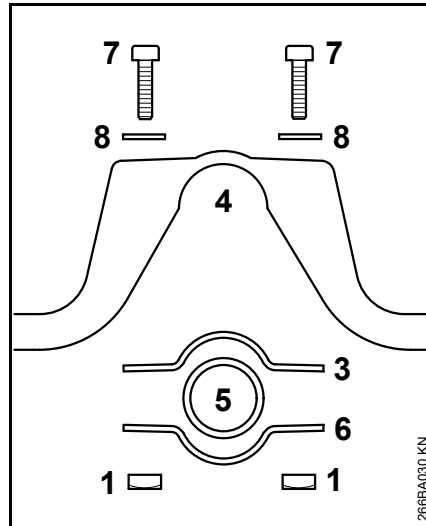

- Place the clamp (3) in the loop handle (4) and position them both against the shaft (5).
- Position the clamp (6) against the shaft.
- Line up the holes.
- Fit the washers (8) on the screws (7), and insert the screws in the holes.
- Screw the square nuts (1) onto the screws (7) as far as stop.
- Go to "Securing the Loop Handle".

Securing the Loop Handle

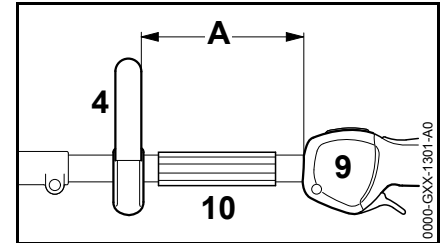

- Secure the loop handle (4) about 20 cm/8 in (A) forward of the control handle (9).
- Line up the loop handle.
- Tighten down the screws firmly – lock the nuts if necessary.

Fitting the Throttle Cable

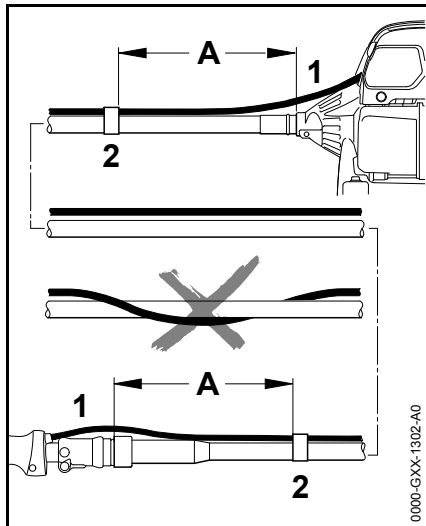

- Push the throttle cable (1) into the two cable retainers (2) about 20 cm/8 in (A) from either end of the shaft.

! WARNING

The whole length of the throttle cable must run parallel to the flexible shaft. Do not wrap the throttle cable around the flexible shaft.

- Go to "Adjusting the Throttle Cable".

Adjusting the Throttle Cable

It may be necessary to correct the adjustment of the throttle cable after assembling the machine or after a prolonged period of operation.

Adjust the throttle cable only when the unit is completely and properly assembled.

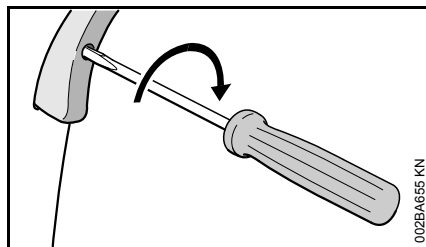

- Set the throttle trigger to the full throttle position.
- Carefully rotate the screw in the throttle trigger in the direction of the arrow until you feel initial resistance. Then rotate it another half turn in the same direction.

Mounting the KombiTool

STIHL brushcutter models with the letter **T** in their designations have a **split drive shaft** for mounting STIHL KombiTools.

Mounting the KombiTool

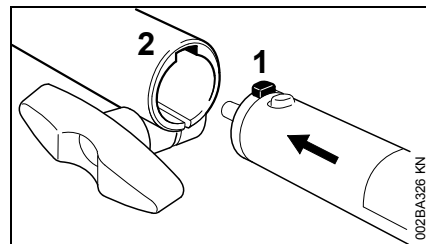

- Push the lug (1) on the drive tube into the slot (2) in the coupling sleeve as far as stop.

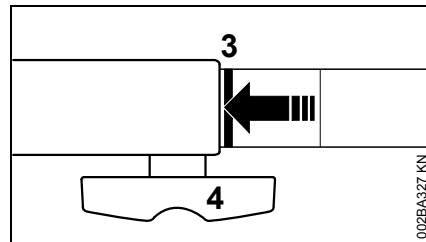

When correctly installed, the red line (3) (arrow point) must be flush with the end of the coupling sleeve.

- Tighten down the star knob (4) **firmly**.

Removing the KombiTool

- Reverse the above sequence to remove the drive tube.

Mounting the deflector

Mounting the Deflector

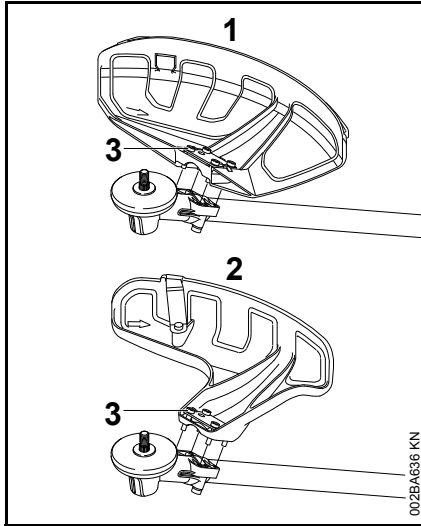

- 1 Deflector for mowing attachments
2 Deflector for mowing heads

Deflectors (1 and 2) are both mounted to the gearbox in the same way.

- Place the deflector on the gearbox flange.
- Insert the screws (3) and tighten them down firmly.

Fitting the Skirt and Blade



WARNING

Risk of injury from thrown objects and contact with the cutting attachment. These parts must be fitted to the deflector (1) when you use a mowing head.

Fitting the Skirt

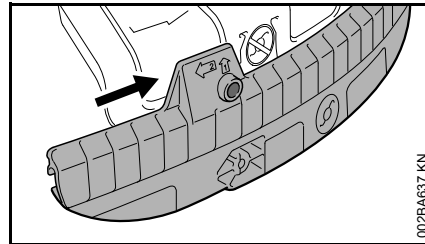

- Slide the lower guide slot of the skirt onto the deflector – it must snap into position.

Removing the Skirt

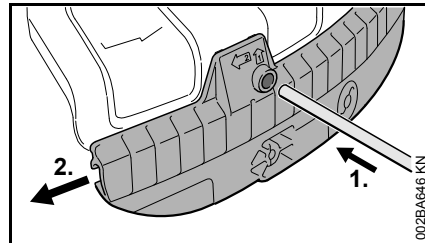

- Insert the stop pin into the hole in the skirt and use it to push the skirt to the left.
- Pull the skirt off the deflector.

Mounting the Blade

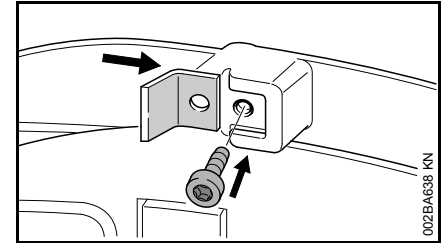

- Slide the line limiting blade into the guide on the skirt.
- Insert the screw and tighten it down firmly.

Mounting the Cutting Attachment

Placing Power Tool on the Ground

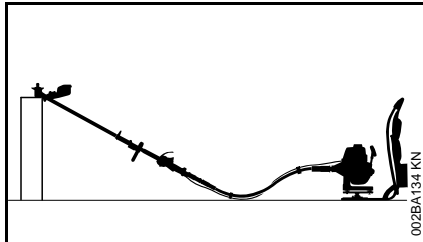

- Shut off the engine.
- Position your power tool so that the cutting attachment mounting face is pointing up.

Mounting Hardware for Cutting Attachments

The mounting hardware supplied depends on the cutting attachment that comes as original equipment with the new machine.

Machine supplied with mounting hardware

Mowing heads and metal cutting attachments may be mounted.

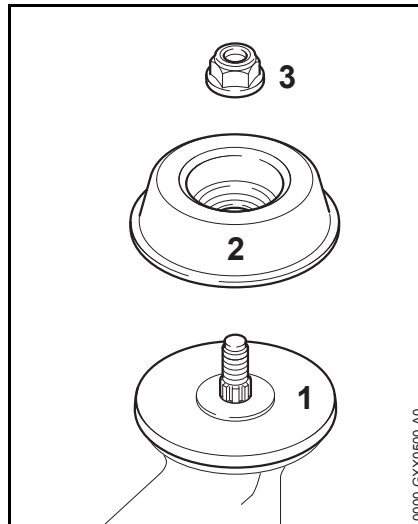

Depending on the cutting attachment, it may be necessary to use the nut (3) and rider plate (2). The thrust plate (1) must be used with all cutting attachments.

These parts are included in a kit supplied with the machine and are also available as special accessories.

Machine supplied without mounting hardware

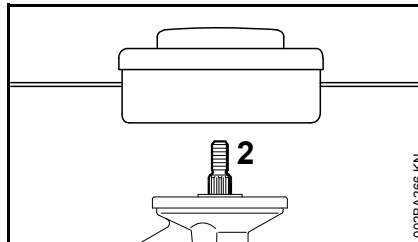

Only mowing heads may be used which mount directly to the shaft (2).

Blocking the Shaft

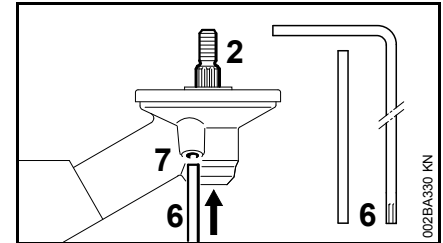

The output shaft (2) must be blocked with the stop pin (6) or screwdriver (6) to mount or remove cutting attachments. These parts come standard with the machine or are available as special accessories.

- Insert the stop pin (6) or screwdriver (6) in the hole (7) in the gearbox as far as stop – and apply slight pressure.
- Rotate shaft, nut or cutting attachment until the stop pin slips into position and blocks the shaft.

Removing the Mounting Hardware

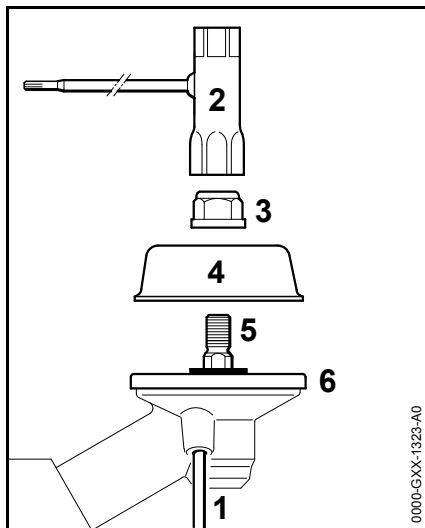

- Block the shaft (5) with the stop pin (1).
- Use the combination wrench (2) to loosen and remove the nut (3) **clockwise** (left-hand thread).
- Take the rider plate (4) off the shaft (5). **Do not** remove the thrust plate (6).

Mounting the Cutting Attachment

WARNING

Risk of injury from thrown objects and contact with the cutting attachment. Use a deflector that matches the cutting attachment – see "Mounting the Deflector".

Fitting Mowing Head with Screw Mounting

Keep the instruction leaflet for the mowing head in a safe place.

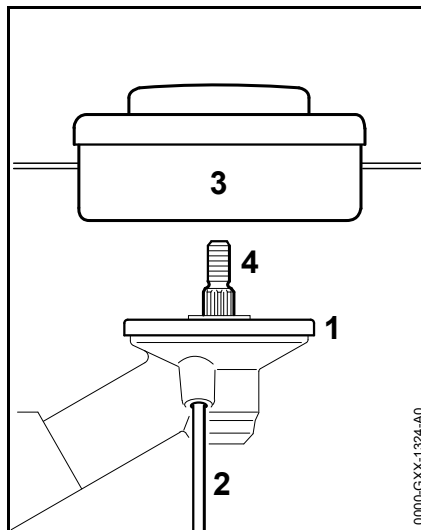

- Fit the thrust plate (1).
- Screw the mowing head (3) counterclockwise on to the shaft (4) as far as stop.
- Block the shaft (4) with the stop pin (2).
- Tighten down the mowing head (3) firmly.

NOTICE

Remove the tool used to block the shaft.

Remove the mowing head.

- Block the shaft (4) with the stop pin (2).
- Unscrew and remove the mowing head (3) clockwise.

Mounting Metal Cutting Attachments

Keep the leaflet and packaging of the metal cutting attachment in a safe place.

WARNING

Wear protective gloves to reduce the risk of direct contact with the sharp cutting edges.

Mount only one metal cutting attachment.

Mount the cutting attachment the right way round

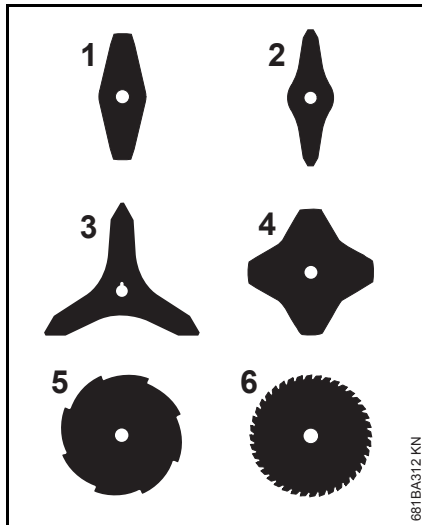

Cutting attachments 1, 2, 3 and 4 may be mounted either way round – they must be turned over regularly to help avoid one-sided wear.

The cutting edges of cutting attachments 5 and 6 must point clockwise.

Direction of rotation is indicated by an arrow on the inside of the deflector.

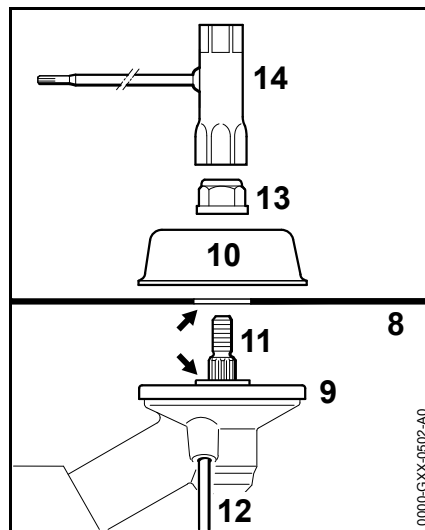

- Fit the thrust plate (9).
- Place the cutting attachment (8) on the thrust plate (9).

Collar (see arrow) must engage the cutting attachment's mounting hole.

Securing the Cutting Attachment

- Fit the rider plate (10).
- Block the shaft (11) with the stop pin (12).
- Use the combination wrench (14) to screw the mounting nut (13) on to the output shaft counterclockwise and tighten it down firmly.

! WARNING

There is a risk of injury if the cutting attachment works loose. If the mounting nut has become too loose, fit a new one.

! NOTICE

Remove the tool used to block the shaft.

Removing the Metal Cutting Attachment

! WARNING

Wear protective gloves to reduce the risk of direct contact with the sharp cutting edges.

- Block the shaft (11) with the stop pin (12).
- Unscrew the mounting nut (13) clockwise.
- Remove cutting attachment and its mounting hardware from the gearbox – but **do not** remove the thrust plate (9).

Fuel

Your engine requires a mixture of gasoline and engine oil.

WARNING

For health reasons, avoid direct skin contact with gasoline and avoid inhaling gasoline vapor.

STIHL MotoMix

STIHL recommends the use of STIHL MotoMix. This ready-to-use fuel mix contains no benzol or lead, has a high octane rating and ensures that you always use the right mix ratio.

STIHL MotoMix uses STIHL HP Ultra two-stroke engine oil for an extra long engine life.

MotoMix is not available in all markets.

Mixing Fuel

NOTICE

Unsuitable fuels or lubricants or mix ratios other than those specified may result in serious damage to the engine. Poor quality gasoline or engine oil may damage the engine, sealing rings, hoses and the fuel tank.

Gasoline

Use only high-quality **brand-name** gasoline with a minimum octane rating of 90 – leaded or unleaded.

Gasoline with an ethanol content of more than 10% can cause running problems in engines with a manually adjustable carburetor and should not be used in such engines.

Engines equipped with M-Tronic deliver full power when run on gasoline with an ethanol content of up to 25% (E25).

Engine Oil

If you mix the fuel yourself, use only STIHL two-stroke engine oil or another high-performance engine oil in accordance with JASO FB, JASO FC, JASO FD, ISO-L-EGB, ISO-L-EGC or ISO-L-EGD.

STIHL specifies STIHL HP Ultra two-stroke engine oil or an equivalent high-performance engine oil in order to maintain emission limits over the machine's service life.

Mix Ratio

STIHL 50:1 two-stroke engine oil: 50 parts gasoline to 1 part oil

Examples

Gasoline Liters	STIHL engine oil 50:1 Liters	(ml)
1	0.02	(20)
5	0.10	(100)
10	0.20	(200)
15	0.30	(300)
20	0.40	(400)
25	0.50	(500)

- Use a canister approved for storing fuel. Pour oil into canister first, then add gasoline and mix thoroughly.

Storing Fuel

Store fuel only in approved safety-type fuel canisters in a dry, cool and safe location protected from light and the sun.

Fuel mix ages – only mix sufficient fuel for a few weeks work. Do not store fuel mix for longer than 30 days. Exposure to light, the sun, low or high temperatures can quickly make the fuel mix unusable.

STIHL MotoMix may be stored for up to 2 years without any problems.

- Thoroughly shake the mixture in the canister before fueling your machine.

WARNING

Pressure may build up in the canister – open it carefully.

- Clean the fuel tank and canister from time to time.

Dispose of remaining fuel and cleaning fluid properly in accordance with local regulations and environmental requirements.

Fueling



Preparations

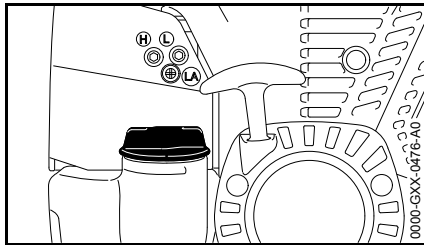

- Before fueling, clean the filler cap and the area around it to ensure that no dirt falls into the tank.
- Position the machine so that the tank cap faces up.

Opening the Tank Cap

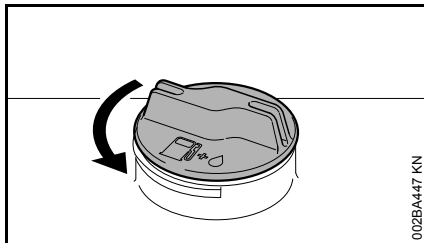

- Turn the cap counterclockwise until it can be removed from the tank opening.
- Remove the tank cap.

Filling Up with Fuel

Take care not to spill fuel while fueling and do not overfill the tank.

STIHL recommends you use the STIHL filler nozzle for fuel (special accessory).

- Fill up with fuel.

Closing the Tank Cap

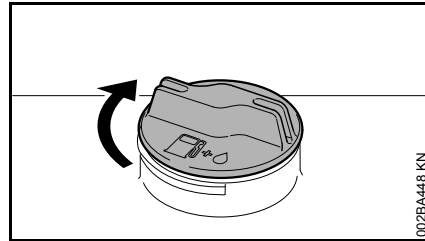

- Place the cap in the opening.
- Turn the cap clockwise as far as stop and tighten it down as firmly as possible by hand.

Support frame

Adjusting the Harness Straps

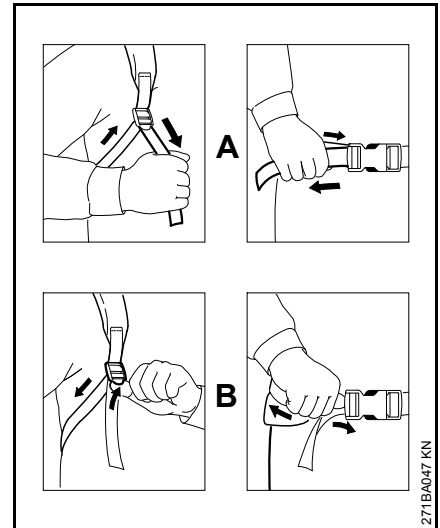

- A** Pull the ends of the straps downward to tighten the harness.
- B** Lift the tabs of the adjusters to loosen the straps.

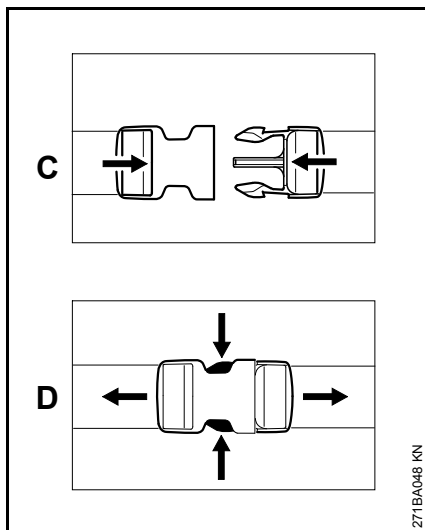

- C** Close and lock the quick-release fastener by pushing it together.
- D** Squeeze the hooks to open the quick-release fastener.

Fitting the Backpack

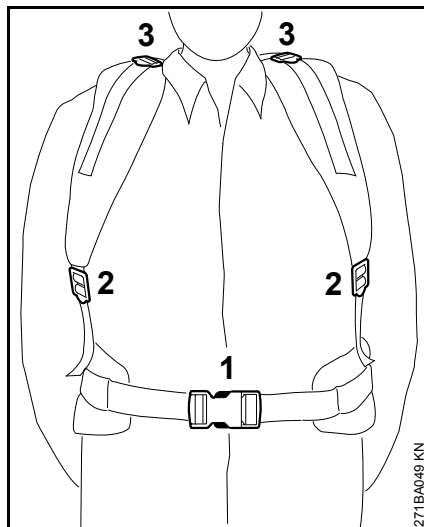

- Close the waist belt (1) and adjust it so that it fits snugly against your hip.
- Adjust the harness straps (2) to the correct length.
- Use the straps (3) to adjust the harness to suit your size.

The back padding must fit firmly and securely against your back.

Removing the Backpack

- Open the quick-release fastener on the waist belt.
- Loosen the harness straps by lifting the sliding adjusters and then take off the backpack.

Throwing Off the Machine



WARNING

The machine and backpack must be quickly thrown off in an emergency. The waist belt **must** be opened before throwing the machine to the ground.

Starting / Stopping the Engine

Controls

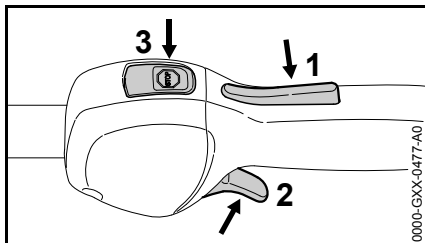

- 1 Throttle trigger lockout
- 2 Throttle trigger
- 3 Stop switch with **Run** and **Stop** positions. Depress the stop switch (☹) to switch off the ignition – see "Function of stop switch and ignition system".



Function of stop switch and ignition system

The ignition is switched off and the engine stopped when the stop switch is pressed. The stop switch returns automatically to the **Run** position when it is released: The ignition is switched on again after the engine stops – the engine is then ready to start.

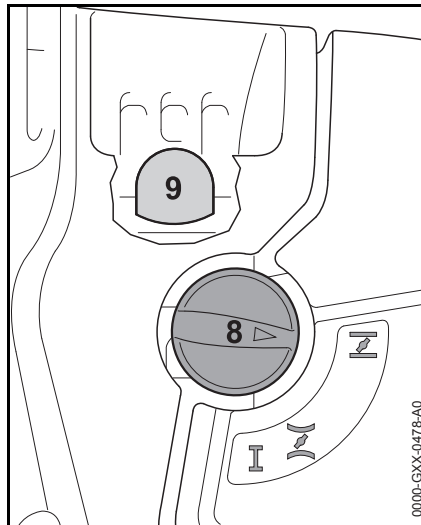
Starting the Engine



- Press the manual fuel pump bulb (9) at least five times – even if the bulb is already filled with fuel.
- Press in the choke knob (8) and turn it to the position that suits the engine temperature:

-  if the engine is cold
-  for warm start – also use this position if the engine has been running but is still cold.

The choke knob must engage in position.

Cranking

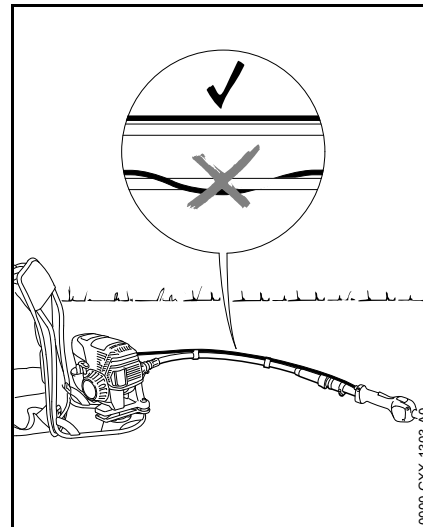

- Put the unit **on the ground**. Make sure it is secure.
- Keep the flexible shaft as straight as possible.

WARNING

The throttle cable must be positioned parallel to the flexible shaft, not wrapped around it.

- If fitted: Remove the transport guard from the attachment.

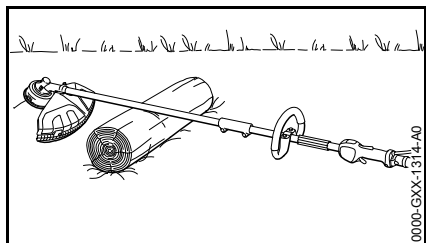
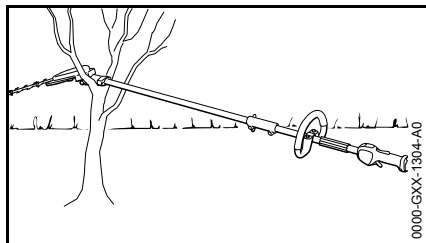

- Rest the KombiTool's gearbox on a raised support, e.g. trestle, forked branch or something similar, to ensure it is clear of the ground.

! WARNING

To reduce the risk of accidents, make sure the attachment and guard are not touching the ground or any other obstacles.

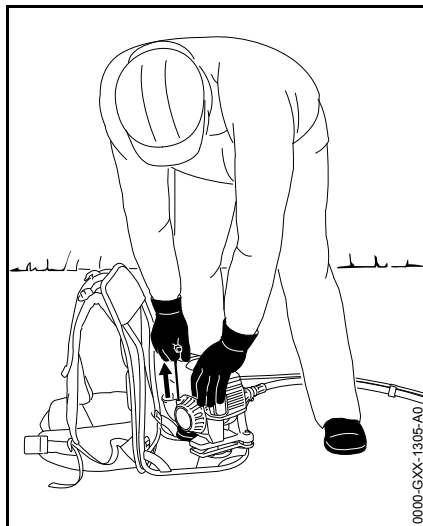

- Make sure you have a firm footing, either standing, stooping or kneeling.
- Hold the unit steady with your left hand on the shroud and put one foot on the support frame and press down.
- Hold the starter grip with your right hand.
- Pull the starter grip slowly until you feel it engage and then give it a brisk strong pull.

⚙ NOTICE

Do not pull out the starter rope all the way – it might otherwise break.

- Do not let the starter grip snap back. Guide it slowly back into the housing so that the starter rope can rewind properly.
- Continue cranking until the engine runs.

As soon as the engine runs

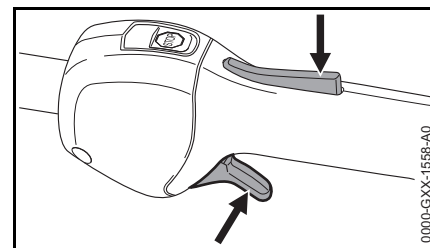

- Press down the throttle trigger lockout and open the throttle – the choke knob moves to the run position I. After a cold start, warm up the engine by opening the throttle several times.

! WARNING

There is a risk of injury if the KombiTool runs when the engine is idling. Adjust the carburetor so that the KombiTool does not run when the engine is idling – see “Adjusting the Carburetor”.

Your machine is now ready for operation.

Stopping the Engine

- Depress the momentary contact stop switch – the engine stops – release the stop switch – it springs back to the run position.

Other Hints on Starting

Engine stalls in cold start position **I** or under acceleration.

- Move the choke knob to **II** and continue cranking until the engine runs.

Engine does not start in warm start position **II**

- Move the choke knob to **I** and continue cranking until the engine runs.

If the engine does not start

- Check that all settings are correct.
- Check that there is fuel in the tank and refuel if necessary.
- Check that the spark plug boot is properly connected.
- Repeat the starting procedure.

Engine is flooded

- Move the choke knob to **I** and continue cranking until the engine runs.

Fuel tank run until completely dry

- After refueling, press the manual fuel pump bulb at least five times – even if the bulb is already filled with fuel.
- Set the choke knob to suit the engine temperature.
- Now start the engine.

Transporting the Unit

Using Transport Guard

The type of transport guard depends on the metal cutting attachment supplied with the machine. Transport guards are available as special accessories.

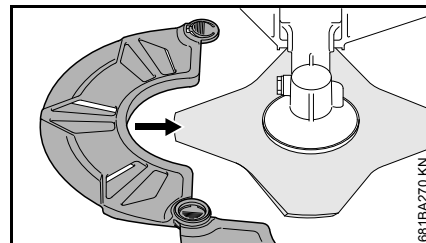

230 mm Grass Cutting Blades

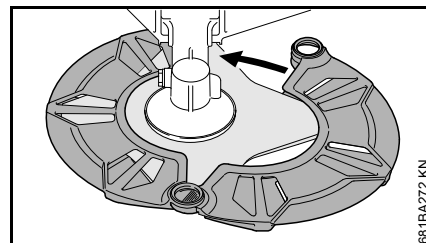
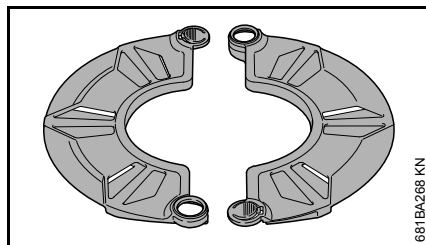

250 mm Brush Knives

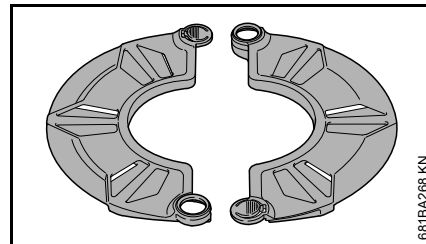
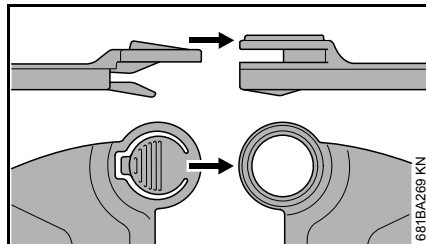

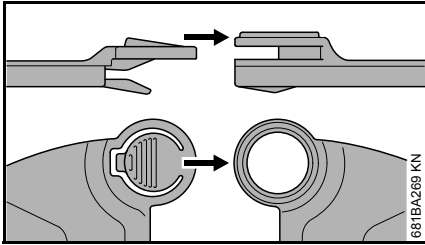

Grass Cutting Blades up to 260 mm

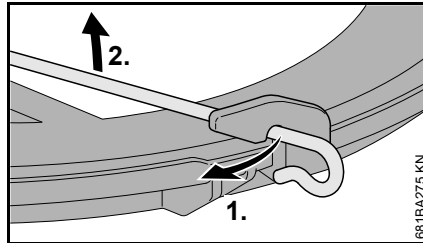
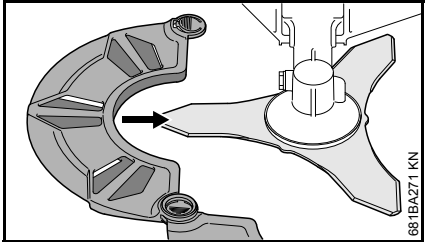
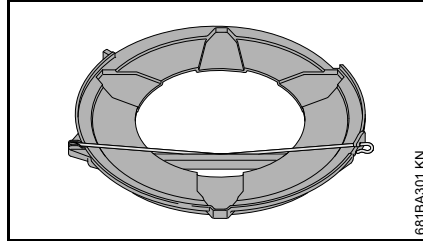

- Disconnect wire rod from the transport guard.
- Swing wire rod outwards.

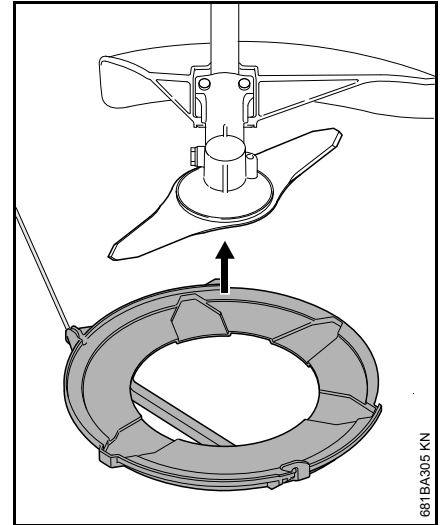
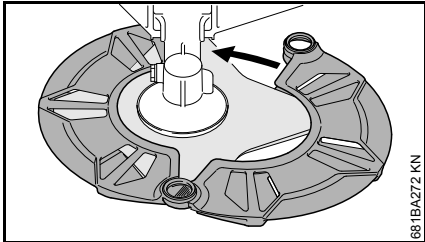

- Fit the transport guard on the cutting attachment from below.

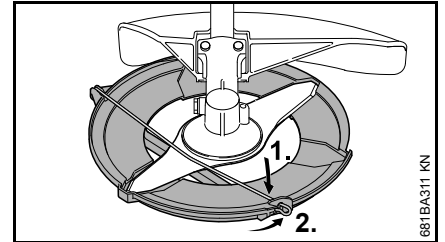

- Swing wire rod into position.
- Hook wire rod to the transport guard.

Operating Instructions

During break-in period

A factory-new machine should not be run at high revs (full throttle off load) for the first three tank fillings. This avoids unnecessary high loads during the break-in period. As all moving parts have to bed in during the break-in period, the frictional resistances in the engine are greater during this period. The engine develops its maximum power after about 5 to 15 tank fillings.

During Operation

After a long period of full throttle operation, allow the engine to run for a short while at idle speed so that engine heat can be dissipated by the flow of cooling air. This protects engine-mounted components (ignition, carburetor) from thermal overload.

After Finishing Work

Storing for a short period: Wait for the engine to cool down. Empty the fuel tank and keep the machine in a dry place, well away from sources of ignition, until you need it again. For longer out-of-service periods – see "Storing the Machine".

Replacing the Air Filter

Filters have an average life of more than a year. Do not remove the filter cover or replace the air filter as long as there is no noticeable loss of power.

If there is a noticeable loss of engine power

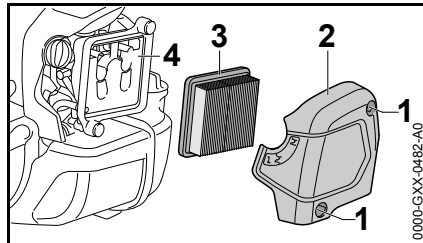

- Turn the choke knob to \bar{I} .
- Loosen the screws (1).
- Remove the filter cover (2).
- Clean away loose dirt from around the filter.
- Remove the filter element (3).
- Replace dirty or damaged filter element (3).
- Replace any damaged parts.

Installing the Filter Element

- Install the filter element (3) in the filter housing and fit the cover.
- Insert the screws (1) and tighten them down firmly.

Adjusting the Carburetor

The carburetor has been set at the factory to provide an optimum fuel-air mixture under most operating conditions.

Adjusting Idle Speed

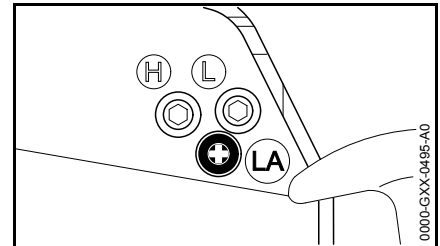

Engine stops while idling

- Warm up the engine for about 3 minutes.
- Turn the idle speed screw (LA) slowly clockwise until the engine runs smoothly – the attachment must not run.

Attachment runs when engine is idling

- Turn the idle speed screw (LA) slowly counterclockwise until the cutting attachment stops running and then turn the screw about another 1/2 to 3/4 turn in the same direction.

! WARNING

If the attachment continues to run when the engine is idling, have your machine checked and repaired by your servicing dealer.

Spark Plug

- If the engine is down on power, difficult to start or runs poorly at idle speed, first check the spark plug.
- Fit a new spark plug after about 100 operating hours – or sooner if the electrodes are badly eroded. Install only suppressed spark plugs of the type approved by STIHL – see "Specifications".

Removing the Spark Plug

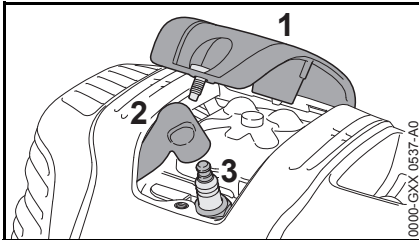

- Remove the cover (1).
- Pull off the spark plug boot (2).
- Unscrew the spark plug (3).

Checking the Spark Plug

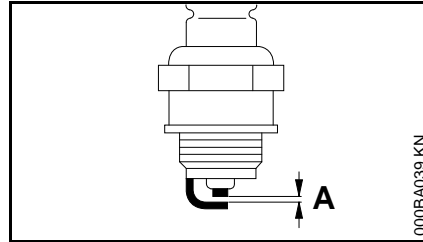

- Clean dirty spark plug.
- Check electrode gap (A) and readjust if necessary – see "Specifications".
- Rectify the problems which have caused fouling of the spark plug.

Possible causes are:

- Too much oil in fuel mix.
- Dirty air filter.
- Unfavorable running conditions.

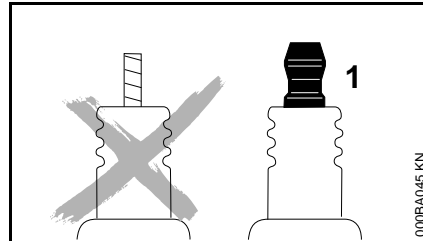

WARNING

Arcing may occur if the adapter nut (1) is loose or missing. Working in an easily combustible or explosive atmosphere may cause a fire or an explosion. This can result in serious injuries or damage to property.

- Use resistor type spark plugs with a properly tightened adapter nut.

Installing the Spark Plug

- Screw the spark plug (3) into the cylinder.
- Tighten down the spark plug (3) with the combination wrench.
- Press the boot (2) firmly onto the spark plug.
- Fit the cover (1) and screw it down firmly.

Engine Running Behavior

If engine running behavior is unsatisfactory even though the air filter is clean and the carburetor is properly adjusted, the cause may be the muffler.

Have the muffler checked for contamination (carbonization) by your servicing dealer.

STIHL recommends that you have servicing and repair work carried out exclusively by an authorized STIHL servicing dealer.

Lubricating the Gearbox

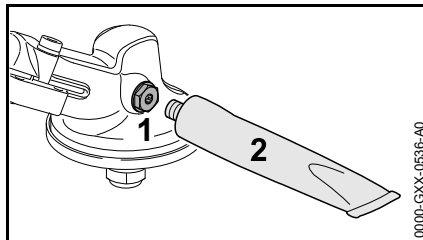

Check grease level after every 25 hours of operation and re-lubricate if necessary.

- Remove the screw plug (1).
- If no grease can be seen on the inside of the screw plug (1): Screw the tube (2) of STIHL gear lubricant (special accessory) into the filler hole.
- Squeeze no more than 5 g (1/5 oz) grease into the gearbox.



NOTICE

Do not completely fill the gearbox with grease.

- Unscrew the tube (2).
- Insert the screw plug (1) and tighten it down firmly.

Lubricating the Flexible Shaft

- Check the film of grease regularly – about every 25 hours of operation.

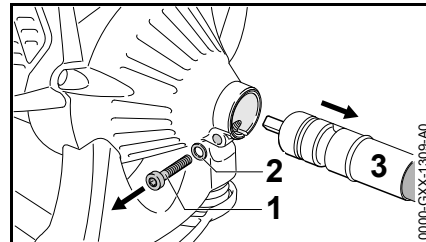

- Unscrew the screw (1) and remove it with the washer (2).
- Pull out the flexible shaft (3).

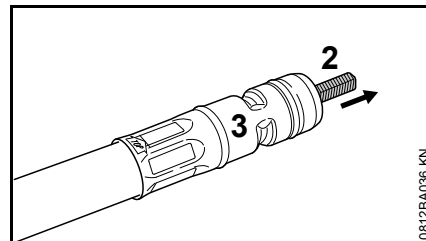

- Pull the flexible shaft (2) out of the protective tube (3).
- Mark the installed position of the flexible tube.
- Coat the shaft uniformly with STIHL multipurpose grease (special accessory). Do not apply too much grease.



NOTICE

If the drive shaft has turned blue, install a new one.

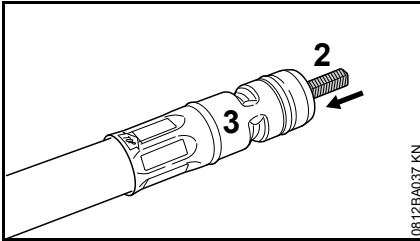

- Refit the flexible shaft (2) in the protective tube (3) – **turn it 180° from the original installed position and push it home as far as stop.**

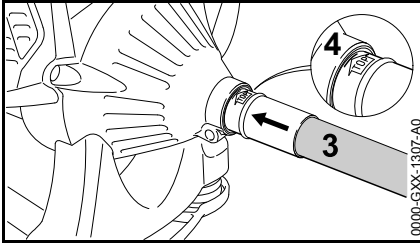

- Push the flexible shaft fully into the powerhead (4) – turn the shaft back and forth at the same time.
- Line up the flexible shaft – the word "Top" must face up.

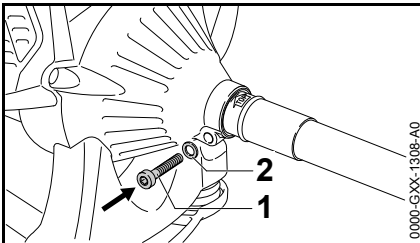

- Insert the screw (1) with washer (2) and tighten it down firmly.

Storing the Machine

For periods of 3 months or longer

- Drain and clean the fuel tank in a well ventilated area.
- Dispose of fuel properly in accordance with local environmental requirements.
- Run the engine until the carburetor is dry – this helps prevent the carburetor diaphragms sticking together.
- Remove, clean and inspect the cutting attachment. Coat metal cutting attachments with corrosion inhibitor.
- Thoroughly clean the machine.
- Clean the air filter.
- Store the machine in a dry and secure location – out of the reach of children and other unauthorized persons.

Sharpening Metal Cutting Blades

- Use a sharpening file (special accessory) to sharpen dull cutting attachments. In case of more serious wear or nicks: Resharpener with a grinder or have the work done by a dealer – STIHL recommends a STIHL servicing dealer.
- Sharpen frequently, take away as little metal as possible – two or three strokes of the file are usually enough.

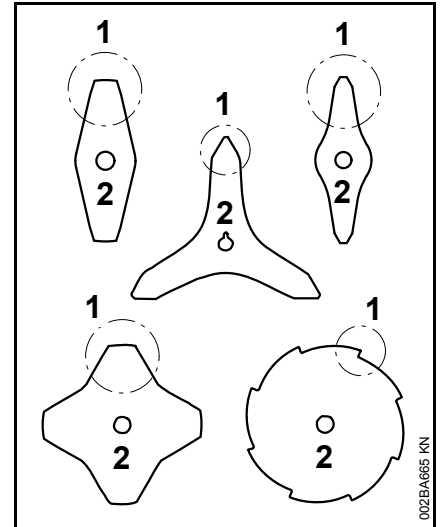

- Resharpener the teeth (1) uniformly – do not alter the contour of the parent blade (2) in any way.

See cutting attachment packaging for additional sharpening instructions. Keep the packaging for future reference.

Balancing

- After resharpening about 5 times, check the cutting attachment for out-of-balance on a STIHL balancer (special accessory) or have it checked by a dealer and re-balanced as necessary – STIHL recommends a STIHL servicing dealer.

Maintaining the Mowing Head

Placing Power Tool on the Ground

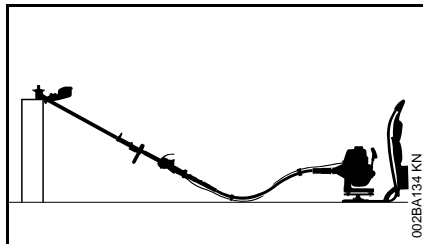

- Shut off the engine.
- Position your power tool so that the cutting attachment mounting face is pointing up.

Replacing Nylon Line

Always check the mowing head for signs of wear before replacing the nylon line.

WARNING

If there are signs of serious wear, replace the complete mowing head.

The nylon mowing line is referred to as "nylon line" or "line" in the following.

The mowing head is supplied with illustrated instructions for replacing the nylon line. Keep the instructions for the mowing head in a safe place.

- If necessary, remove the mowing head.

Adjusting Nylon Line

STIHL SuperCut

Fresh line is advanced automatically if the remaining line is **at least 6 cm (2 1/2 in)** long. The blade on the deflector trims overlong lines to the correct length.

STIHL AutoCut

- With the engine running, hold the rotating mowing head above the grass surface.
- Tap it on the ground once – fresh line is advanced and the blade on the deflector trims it to the right length.

Fresh line is advanced every time the mowing head is tapped on the ground. For this reason observe the mowing head's cutting performance during operation. If the mowing head is tapped on the ground too often, the line limiting blade will unnecessarily cut off unused lengths of nylon line.

Line feed operates only if both lines are still at least **2.5 cm (1 in)** long.

STIHL TrimCut

WARNING

To reduce the risk of injury, always shut off the engine before adjusting the nylon line by hand.

- Pull the spool up – rotate it about 1/6 turn counterclockwise until it engages – and allow it to spring back.
- Pull ends of the lines outward.

Repeat the above procedure as necessary until both lines reach the limiter blade on the deflector.

Rotating the spool from one stop to the next advances about 4 cm (1 1/2 in) of fresh line.

Replacing Nylon Line

STIHL PolyCut

Precut lengths of nylon line can be fitted to the PolyCut in place of the cutting blades.

STIHL DuroCut, STIHL PolyCut

! WARNING

To reduce the risk of injury, always shut off the engine before refilling the mowing head.

- Fit precut lengths of nylon line in the mowing head as described in the instructions supplied.

Replacing Cutting Blades

STIHL PolyCut

Always check the mowing head for signs of wear before installing new cutting blades.

! WARNING

If there are signs of serious wear, replace the complete mowing head.

The thermoplastic cutting blades are referred to as "blades" in the following.

The mowing head is supplied with illustrated instructions for replacing the blades. Keep the instructions for the mowing head in a safe place.

! WARNING

To reduce the risk of injury, always shut off the engine before installing the blades.

- Remove the mowing head.
- Replace blades as shown in the illustrated instructions.
- Mount the mowing head on the machine.

Inspections and Maintenance by Dealer

Maintenance Work

STIHL recommends that you have servicing and repair work carried out exclusively by an authorized STIHL servicing dealer.

Anti-Vibration Elements

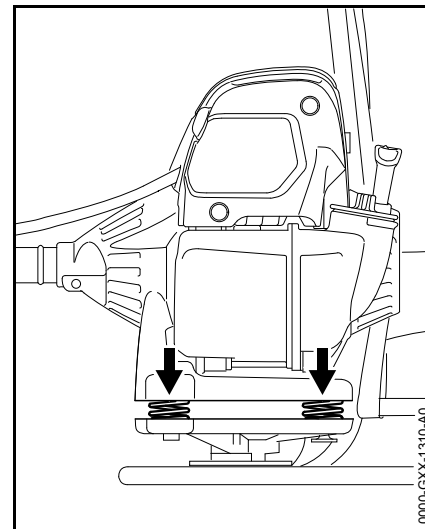

Four anti-vibration springs are installed between the powerhead and support frame. Have them checked if there are signs of wear or a noticeable increase in vibration levels.

Maintenance and Care

The following intervals apply to normal operating conditions only. If your daily working time is longer or operating conditions are difficult (very dusty work area, etc.), shorten the specified intervals accordingly.		before starting work	after finishing work or daily	after each refueling stop	weekly	monthly	every 12 months	if problem	if damaged	as required
Complete machine	Visual inspection (condition, leaks)	X		X						
	Clean		X							
	Replace any damaged parts	X							X	
Control handle	Check operation	X		X						
Air filter	Visual inspection					X		X		
	Replace ²⁾								X	
Manual fuel pump (if fitted)	Check	X								
	Have repaired by servicing dealer ¹⁾								X	
Pickup body (filter) in fuel tank	Have checked by servicing dealer ¹⁾							X		
	Have replaced by servicing dealer ¹⁾						X		X	X
Fuel tank	Clean							X		X
Carburetor	Check idle adjustment – the working/cutting attachment must not run	X		X						
	Adjust idle speed									X
Spark plug	Adjust electrode gap							X		
	Replace after every 100 operating hours									
Cooling air inlet	Visual inspection		X							
	Clean									X
Cylinder fins	Have cleaned by servicing dealer ¹⁾						X			
Valve clearance	If power is low or cranking effort very high, have valve clearance checked and, if necessary, adjusted by servicing dealer ¹⁾							X		X
Combustion chamber	Have cleaned after every 150 hours of operation by servicing dealer ¹⁾									X

The following intervals apply to normal operating conditions only. If your daily working time is longer or operating conditions are difficult (very dusty work area, etc.), shorten the specified intervals accordingly.		before starting work	after finishing work or daily	after each refueling stop	weekly	monthly	every 12 months	if problem	if damaged	as required
All accessible screws and nuts (not adjusting screws)	Retighten									X
Antivibration elements	Check	X						X		X
	Have replaced by servicing dealer ¹⁾								X	
Cutting attachment	Visual inspection	X		X						
	Replace								X	
	Check tightness	X		X						
Metal cutting attachment	Sharpen	X								X
Flexible shaft	Check				X					
	Replenish film of lubricant									X
Gearbox lubrication	Check				X					
	Replenish									X
Safety labels	Replace								X	

¹⁾ STIHL recommends an authorized STIHL servicing dealer.

²⁾ Only if there is a noticeable loss of engine power

Minimize Wear and Avoid Damage

Observing the instructions in this manual helps reduce the risk of unnecessary wear and damage to the power tool.

The power tool must be operated, maintained and stored with the due care and attention described in this owner's manual.

The user is responsible for all damage caused by non-observance of the safety precautions, operating and maintenance instructions in this manual. This includes in particular:

- Alterations or modifications to the product not approved by STIHL.
- Using tools or accessories which are neither approved or suitable for the product or are of a poor quality.
- Using the product for purposes for which it was not designed.
- Using the product for sports or competitive events.
- Consequential damage caused by continuing to use the product with defective components.

Maintenance Work

All the operations described in the "Maintenance Chart" must be performed on a regular basis. If these maintenance operations cannot be performed by the owner, they should be performed by a servicing dealer.

STIHL recommends that you have servicing and repair work carried out exclusively by an authorized STIHL

servicing dealer. STIHL dealers are regularly given the opportunity to attend training courses and are supplied with the necessary technical information.

If these maintenance operations are not carried out as specified, the user assumes responsibility for any damage that may occur. Among other parts, this includes:

- Damage to the engine due to neglect or deficient maintenance (e.g. air and fuel filters), incorrect carburetor adjustment or inadequate cleaning of cooling air inlets (intake ports, cylinder fins).
- Corrosion and other consequential damage resulting from improper storage.
- Damage to the machine resulting from the use of poor quality replacement parts.

Parts Subject to Wear and Tear

Some parts of the power tool are subject to normal wear and tear even during regular operation in accordance with instructions and, depending on the type and duration of use, have to be replaced in good time. Among other parts, this includes:

- Cutting attachments (all types)
- Mounting hardware for cutting attachments (rider plate, nut, etc.)
- Deflectors for cutting attachments
- Clutch
- Filters (air, fuel)
- Rewind starter

- Spark plug
- Antivibration elements

Main Parts

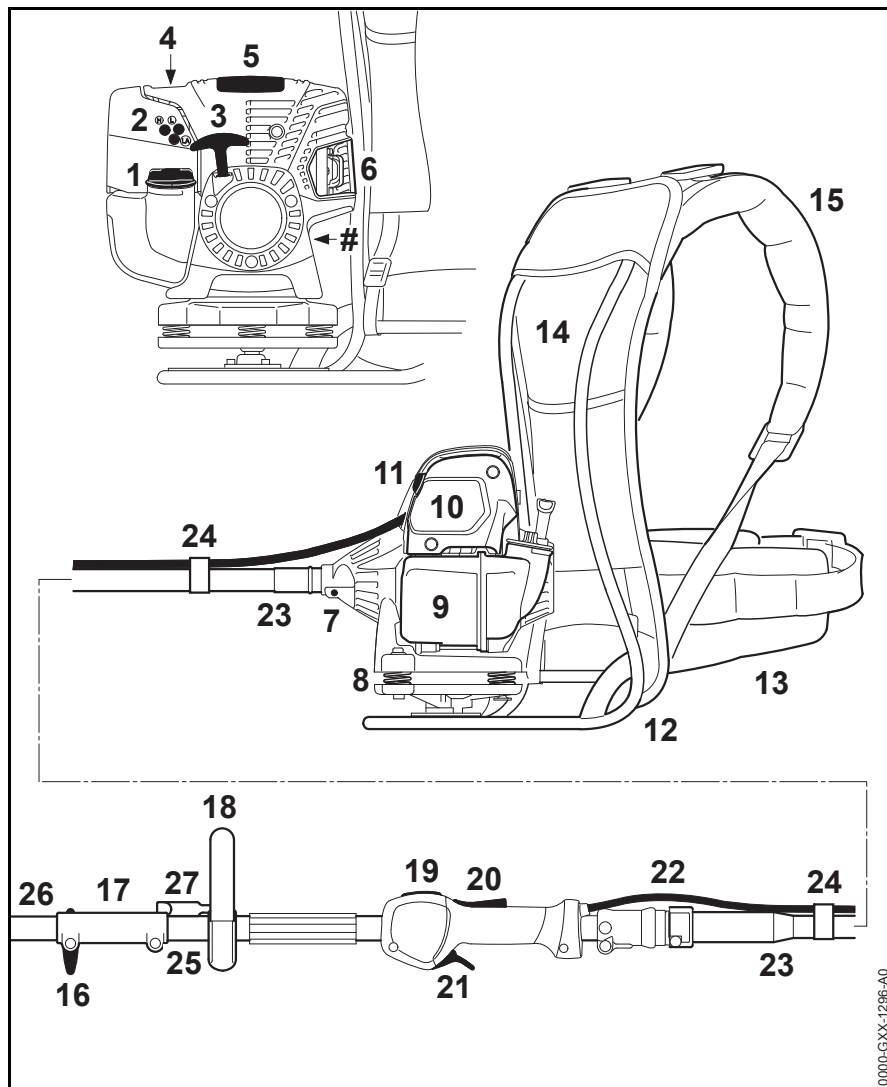

- 1 Tank cap
- 2 Carburetor adjusting screw
- 3 Starter grip
- 4 Manual fuel pump
- 5 Cover
- 6 Muffler
- 7 Screw
- 8 Antivibration element
- 9 Fuel tank
- 10 Air filter cover
- 11 Choke knob
- 12 Support frame
- 13 Hip/waist belt
- 14 Back padding
- 15 Harness
- 16 Wing screw
- 17 Coupling sleeve
- 18 Loop handle
- 19 Stop switch
- 20 Throttle trigger lockout
- 21 Throttle trigger
- 22 Throttle cable
- 23 Flexible shaft
- 24 Cable holder
- 25 Drive tube (basic powerhead)
- 26 Drive tube (KombiTool)
- 27 Barrier bar
- # Serial number

0000-GXX-1296-A0

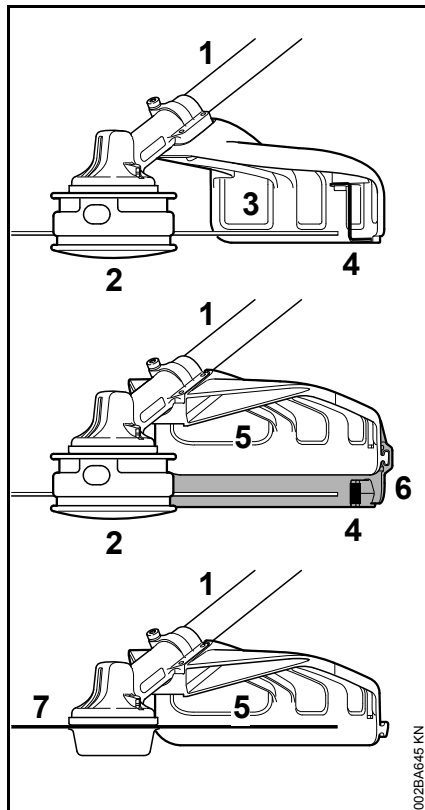

002BA645 KN

- 1 Drive tube
- 2 Mowing head
- 3 Deflector for mowing heads only
- 4 Blade
- 5 Deflector for all mowing attachments
- 6 Skirt
- 7 Metal mowing attachment

Specifications

Engine

STIHL single cylinder four-stroke engine with mixture lubrication

Displacement:	36.3 cc
Bore:	43 mm
Stroke:	25 mm
Engine power to ISO 8893:	1.4 kW (1.9 bhp) at 8,500 rpm
Idle speed:	2,800 rpm
Cut-off speed (rated):	9,500 rpm
Max. output shaft speed (cutting attachment):	7,150 rpm
Valve clearance	
Inlet valve:	0.10 mm
Exhaust valve:	0.10 mm

Ignition System

Electronic magneto ignition

Spark plug (resistor type):	NGK CMR 6 H
Electrode gap:	0.5 mm

Fuel System

All position diaphragm carburetor with integral fuel pump

Fuel tank capacity:	710 cc (0.71 l)
---------------------	-----------------

Weight

Dry, with FS-KM KombiTool, without cutting attachment and deflector
9.6 kg

Overall length

without KombiTool: 1800 mm

Features

T Split boom (drive tube)

Noise and Vibration Data

For further details on compliance with Vibration Directive 2002/44/EC visit www.stihl.com/vib.

FS-KM KombiTool

Noise and vibration data measurements include idling and rated maximum speed with the same duration of exposure.

Sound pressure level L_p to ISO 22868

with mowing head	97 dB(A)
with metal mowing attachment	97 dB(A)

Sound power level L_w to ISO 22868

with mowing head	110 dB(A)
with metal mowing attachment	109 dB(A)

Vibration level $a_{hv,eq}$ to ISO 22867 at maximum RPM

	Handle, left	Handle, right
with mowing head:	4.7 m/s ²	4.3 m/s ²
with metal mowing attachment	3.9 m/s ²	2.9 m/s ²

Other KombiTools

For version see "Approved KombiTools".

Noise and vibration data measurements include idling and rated maximum speed in the following ratios.

FCS-KM, FCB-KM, FSB-KM, FH-KM and HT-KM	1 to 1
HL-KM	1 to 4
BF-KM and BG-KM	1 to 6

Sound pressure level L_p to EN ISO 10517, ISO 11201, ISO 22868

92 dB(A)...101 dB(A)

Sound power level L_w to ISO 3744, ISO 10517, ISO 22868

109 dB(A)...110 dB(A)

Sound power level L_w to ISO 3744, ISO 10517, ISO 22868

106 dB(A)...110 dB(A)

Vibration level $a_{hv,eq}$ to ISO 11789, ISO 20643, ISO 22867, ISO 8662**Handle, left**

1.3 m/s²...8.5 m/s²

Handle, right

1.3 m/s²...5.3 m/s²

The K-factor in accordance with Directive 2006/42/EC is 2.0 dB(A) for the sound pressure level and sound power level; the K-factor in accordance with Directive 2006/42/EC is 2.0 m/s² for the vibration level.

REACH

REACH is an EC regulation and stands for the Registration, Evaluation, Authorisation and Restriction of Chemical substances.

For information on compliance with the REACH regulation (EC) No. 1907/2006 see www.stihl.com/reach.

Exhaust Emissions

The CO₂ value measured in the EU type approval procedure is specified at www.stihl.com/co2.

The measured CO₂ value was determined on a representative engine in accordance with a standardized test procedure under laboratory conditions and does not represent either an explicit or implied guarantee of the performance of a specific engine.

The applicable exhaust emission requirements are fulfilled by the intended usage and maintenance described in this instruction manual. The type approval expires if the engine is modified in any way.

Maintenance and Repairs

Users of this machine may only carry out the maintenance and service work described in this user manual. All other repairs must be carried out by a servicing dealer.

STIHL recommends that you have servicing and repair work carried out exclusively by an authorized STIHL servicing dealer. STIHL dealers are regularly given the opportunity to attend training courses and are supplied with the necessary technical information.

When repairing the machine, only use replacement parts which have been approved by STIHL for this power tool or are technically identical. Only use high-quality replacement parts in order to avoid the risk of accidents and damage to the machine.

STIHL recommends the use of original STIHL replacement parts.

Original STIHL parts can be identified by the STIHL part number, the **STIHL** logo and the STIHL parts symbol  (the symbol may appear alone on small parts).

Disposal

Observe all country-specific waste disposal rules and regulations.

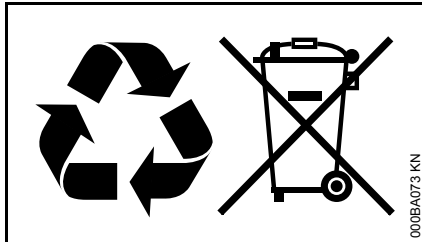

STIHL products must not be thrown in the garbage can. Take the product, accessories and packaging to an approved disposal site for environment-friendly recycling.

Contact your STIHL servicing dealer for the latest information on waste disposal.

EC Declaration of Conformity

ANDREAS STIHL AG & Co. KG
Badstr. 115
D-71336 Waiblingen

Germany

declare in exclusive responsibility that

Category:	Backpack brushcutter
Make:	STIHL
Model:	FR 131 T
Serial identification:	4180
Displacement:	36.3 cc

conforms to the relevant provisions of Directives 2011/65/EU, 2006/42/EC, 2014/30/EU and 2000/14/EC and has been developed and manufactured in compliance with the following standards in the versions valid on the date of production:

EN ISO 11806-2, EN 55012,
EN 61000-6-1 (in conjunction with the following KombiTools: BF-KM, BG-KM, FCB-KM, FCS-KM, FH-KM, FS-KM, FSB-KM, HL-KM and HT-KM)

The basic power tool described here may be operated only in conjunction with the KombiTools approved by STIHL for use with this specific basic power tool.

The measured and guaranteed sound power levels were determined according to Directive 2000/14/EC, Annex V, using the ISO 10884 (FS) standard.

Measured sound power level:

110 dB(A)

Guaranteed sound power level:

112 dB(A)

Technical documents deposited at:

ANDREAS STIHL AG & Co. KG
Produktzulassung (Product Licensing)

The year of manufacture and serial number are applied to the product.

Done at Waiblingen, 27.11.2018

ANDREAS STIHL AG & Co. KG

A handwritten signature in black ink that reads 'Thomas Elsner'.

Thomas Elsner

Director Product Management and Services

The CE mark, consisting of the letters 'C' and 'E' in a stylized, bold font.

0458-434-0121-A

englisch



www.stihl.com



0458-434-0121-A